

PARKING LIGHT WIRE (-)

- If the aftermarket system has a (-) negative parking light output, this may be connected directly to the vehicle's (-) parking light wire. If the aftermarket system only has a (+) positive parking light output, a relay must be used to interface. Use a relay and wire as shown:

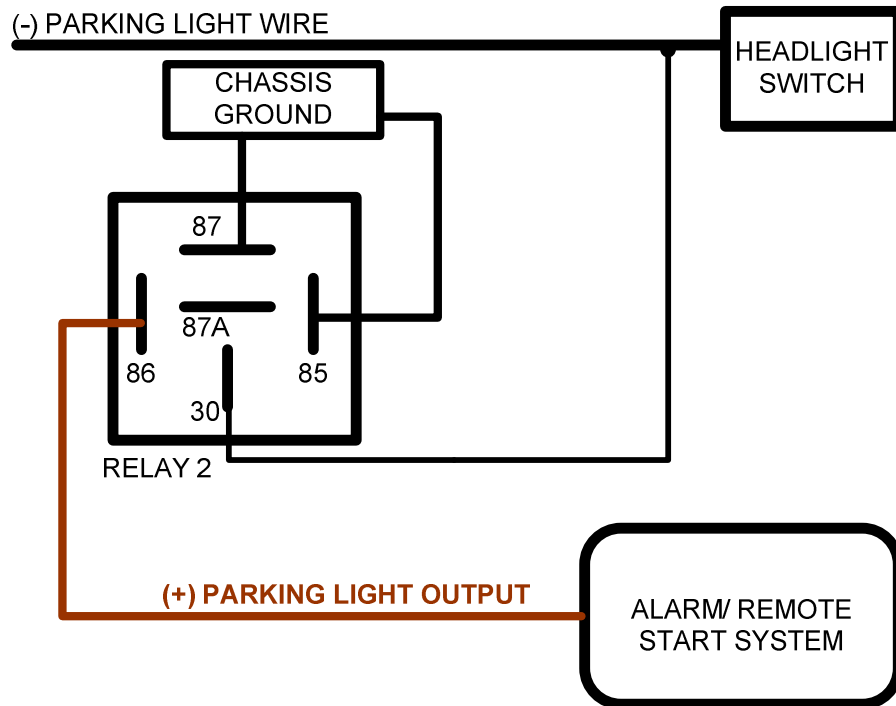

PIN	CONNECTION
85	TO CHASSIS GROUND
86	TO (+) PARKING LIGHT OUTPUT FROM ALARM/REMOTE START SYSTEM
87	TO CHASSIS GROUND
87A	NO CONNECTION
30	TO VEHICLE (-) PARKING LIGHT WIRE

Remote starter and security installations should be attempted by experienced security installers only. Information contained is accurate to the best of our knowledge and experience. Information contained is without any representation of warranty. It is the installer's responsibility to test and confirm all circuits with a digital multi-meter. Proper installation remains the responsibility of the installer. CarInstallExperts.com assumes no liability or responsibility resulting from an improper installation, even in reliance with the information contained in this guide.